

BC

Basic Pedestal



Self Priming Centrifugal Pump

Model 02C3-B

Size 2" x 2"

PUMP SPECIFICATIONS

- Size:** 2" x 2" (51 mm x 51 mm) NPT – Female.
- Casing:** Gray Iron No. 30.
Maximum Operating Pressure 34 psi (234 kPa).*
- Enclosed Type, Five Vane, Impeller:** Copper Alloy C83600.
Handles 11/32" (8,7 mm) Diameter Spherical Solids.
- Impeller Shaft:** Steel No. 1215.
- Replaceable Vane Plate:** Gray Iron No. 30.
- Bearing Housing:** Gray Iron No. 30.
- Intermediate:** Gray Iron No. 30.
- Thrust and Radial Bearings:** Sealed Single Row Ball.
- Gaskets:** NC710 Cork ^{w/}Nitrile Binder.
- O-Ring:** Fluorocarbon (DuPont Viton[®] or Equivalent).
- Hardware:** Standard Plated Steel.
- Optional Equipment:** All Iron Construction. Ductile Iron Cas-
ing.

**Consult Factory for Applications Exceeding Maximum Pressure and/or Temperature Indicated.*



SEAL SPECIFICATIONS

Type 21, Mechanical, Self-Lubricated. Carbon Rotating Face. Ni-Resist Stationary Face. Fluorocarbon Elastomers (DuPont Viton[®] or Equivalent). Stainless Steel No. 18-8 Cage and Spring. Maximum Temperature of Liquid Pumped, 160°F. (71°C).*

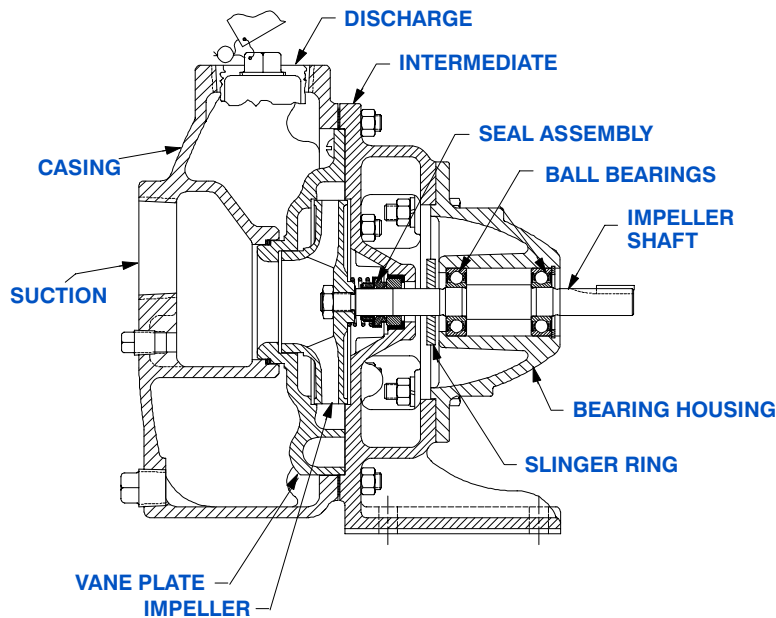

SEAL DETAIL

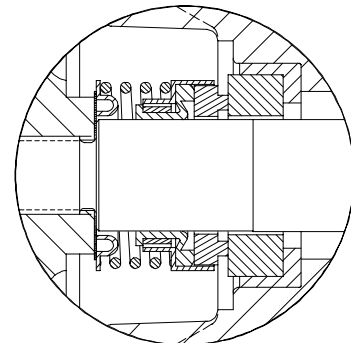

THE GORMAN-RUPP COMPANY • MANSFIELD, OHIO

GORMAN-RUPP OF CANADA LIMITED • ST. THOMAS, ONTARIO, CANADA

www.gormanrupp.com

Specifications Subject to Change Without Notice

Printed in U.S.A.

Specification Data

SECTION 30, PAGE 325

APPROXIMATE
DIMENSIONS and WEIGHTS

NET WEIGHT:
SHIPPING WEIGHTS:
EXPORT CRATE:

50 POUNDS (22,6 kg)
55 POUNDS (24,9 kg)
2.3 CU. FT (0,06 CU. M.)

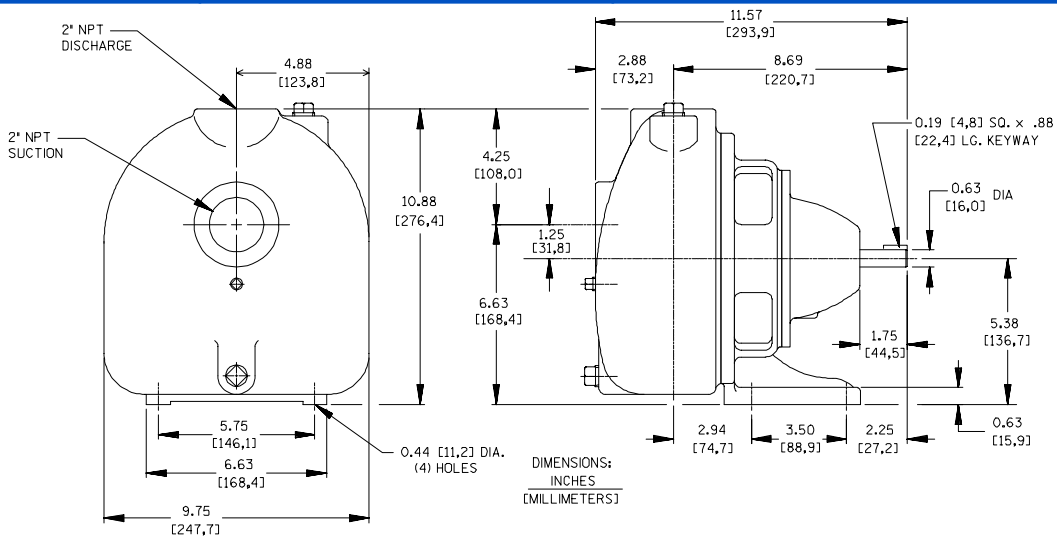

**PERFORMANCE
BASED ON
PETROLEUM**

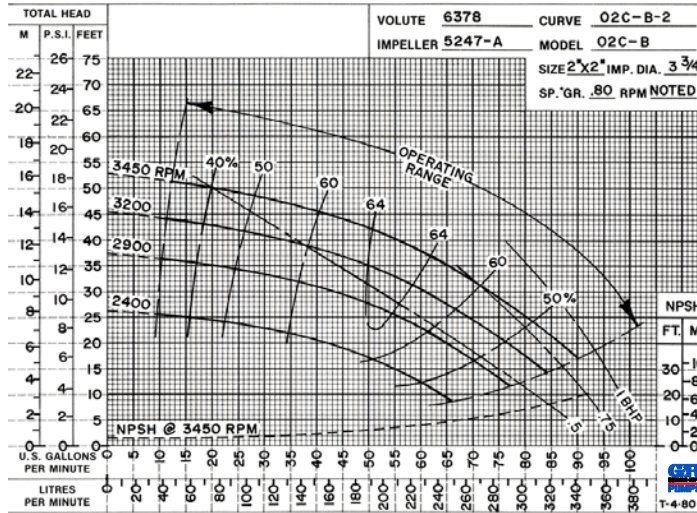

**PERFORMANCE
BASED ON
WATER**

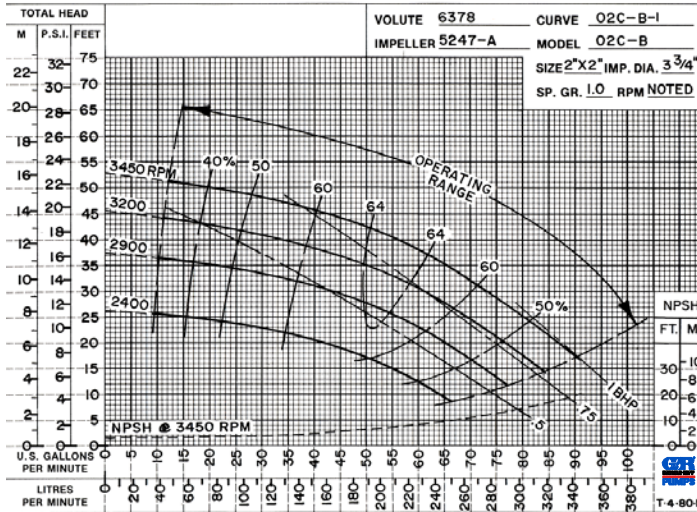

THE GORMAN-RUPP COMPANY • MANSFIELD, OHIO

GORMAN-RUPP OF CANADA LIMITED • ST. THOMAS, ONTARIO, CANADA

Specifications Subject to Change Without Notice

Printed in U.S.A.