

BC

Basic Pedestal



Self Priming Centrifugal Pump

Models 02K3-B, 02K11-B and 02K31-B

Size 2" x 2"

PUMP SPECIFICATIONS

Size: 2" x 2" (51 mm x 51 mm) NPT – Female.

Casing:

(02K3-B and 02K11-B): Gray Iron 30.

(02K31-B): Ductile Iron 60-40-18.

Maximum Operating Pressure 55 psi (379 kPa).*

Enclosed Type, Four Vane Impeller: Copper Alloy C83600.

Handles 3/8" (9,5 mm) Diameter Spherical Solids.

Impeller Shaft: (02K3-B and 02K31-B): Carbon Steel 1215.

(02K11-B): Stainless Steel 303/304.

Replaceable Vane Plate: Gray Iron 30.

Intermediate:

(02K3-B and 02K11-B): Gray Iron 30.

(02K31-B): Ductile Iron 60-40-18.

Bearing Housing: Gray Iron 30.

Thrust and Radial Bearings: Sealed Single Row Ball Type.

Gaskets:

(02K3-B and 02K31-B): Cork w/Nitrile Binder NC710.

(02K11-B): PTFE.

O-Ring: Fluorocarbon (DuPont Viton® or Equivalent).

Hardware: Standard Plated Steel.

Optional Equipment: All Iron Construction.

**Consult Factory for Applications Exceeding Maximum Pressure and/or Temperature Indicated.*

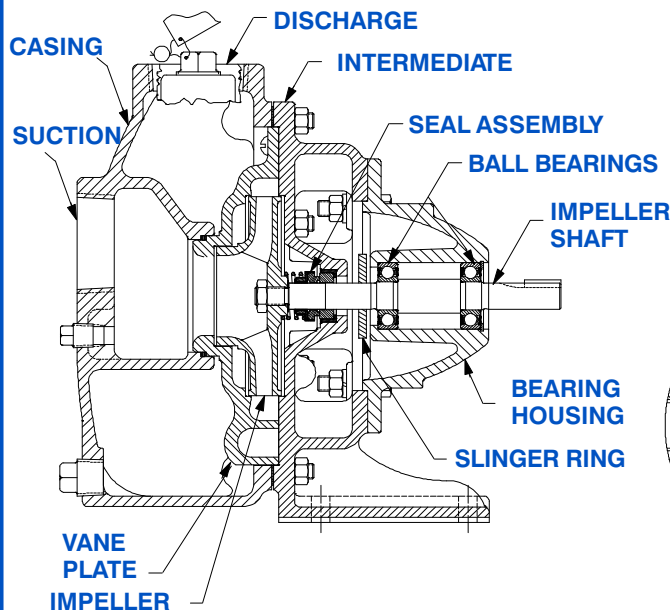

SEAL DETAIL:

02K3-B and 02K31-B

Type 21, Mechanical, Self-Lubricated. Carbon Rotating Face. Ni-Resist Stationary Face. Fluorocarbon Elastomers (DuPont Viton® or Equivalent). Stainless Steel 18-8 Cage and Spring. Maximum Temperature of Liquid Pumped, 160°F. (71°C).*

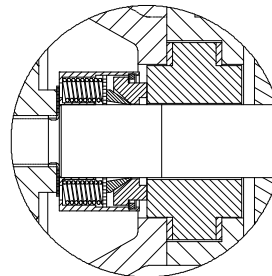
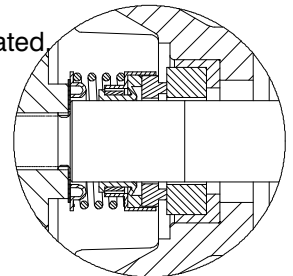

SEAL DETAIL:

02K11-B

Type 9, Mechanical, Self-Lubricated. Carbon Rotating Face. Ceramic Stationary Face. PTFE Elastomers. Stainless Steel 316 Cage and Spring. Maximum Temperature of Liquid Pumped, 160°F. (71°C).*



THE GORMAN-RUPP COMPANY • MANSFIELD, OHIO

GORMAN-RUPP OF CANADA LIMITED • ST. THOMAS, ONTARIO, CANADA

www.grpumps.com

Specifications Subject to Change Without Notice

Printed in U.S.A.

Specification Data

SECTION 30, PAGE 825

APPROXIMATE
DIMENSIONS and WEIGHTS

NET WEIGHT:
SHIPPING WEIGHT:
EXPORT CRATE:

46 LBS. (21 KG.)
56 LBS. (25 KG.)
2.3 CU FT. (1.76 CU. M.)

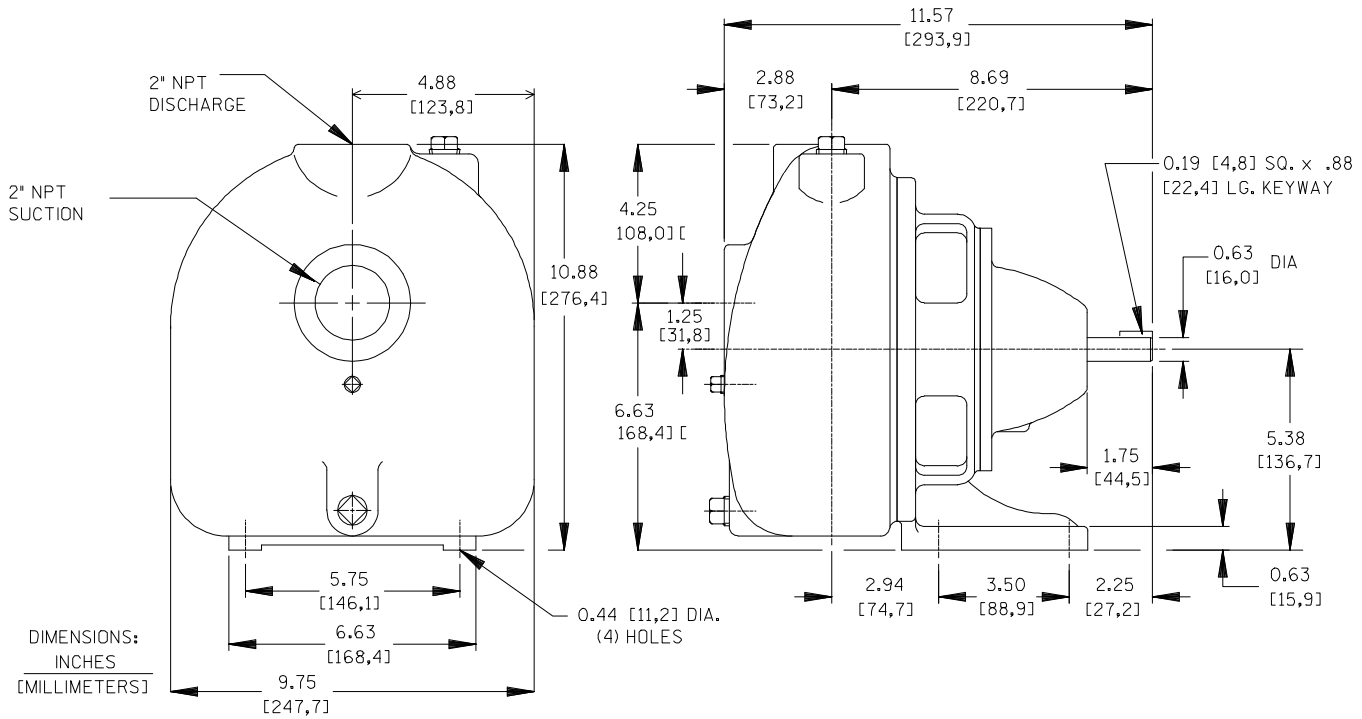

PERFORMANCE
BASED ON
WATER

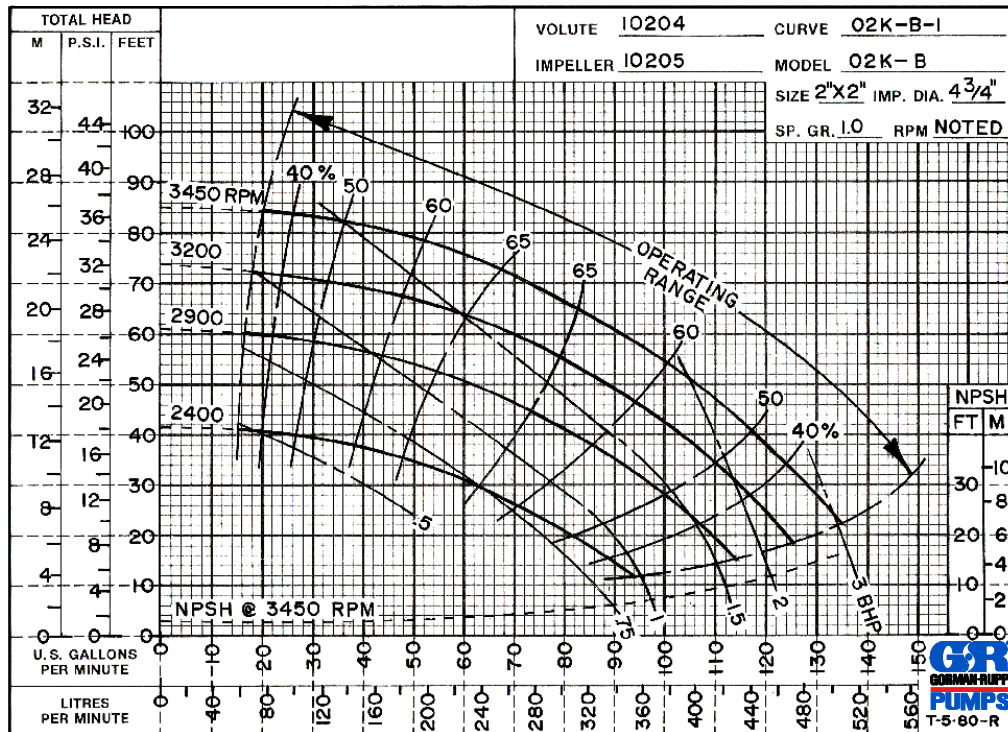

THE GORMAN-RUPP COMPANY • MANSFIELD, OHIO

GORMAN-RUPP OF CANADA LIMITED • ST. THOMAS, ONTARIO, CANADA

Specifications Subject to Change Without Notice

Printed in U.S.A.

B C

PERFORMANCE
BASED ON
PETROLEUM

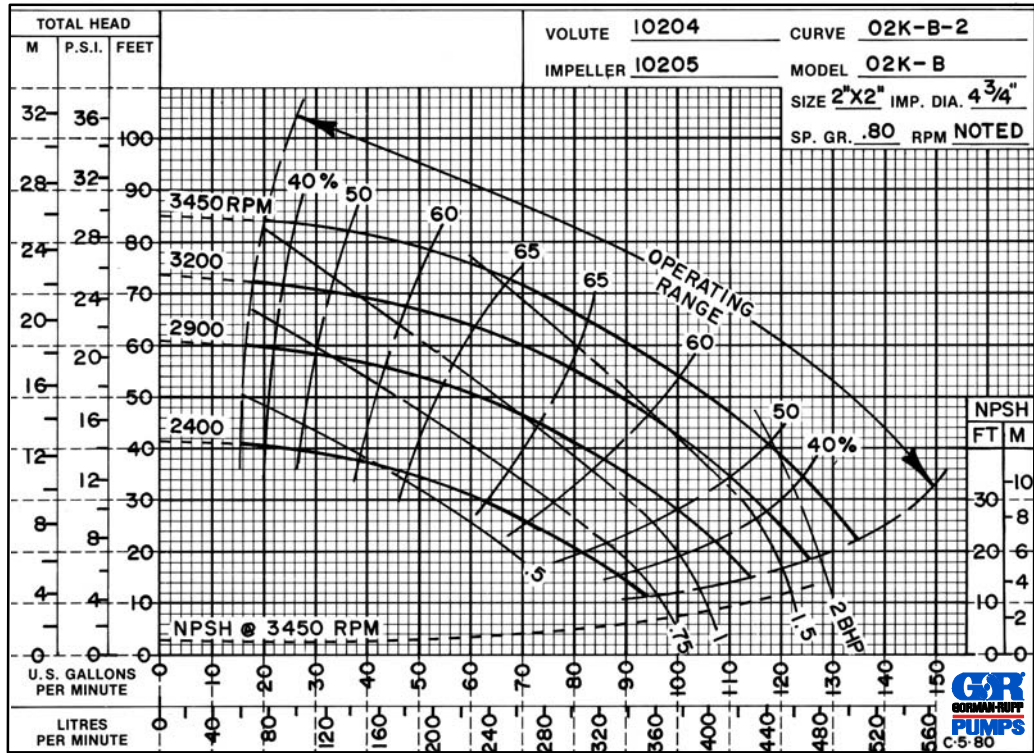

50 HERTZ
PERFORMANCE
BASED ON
WATER

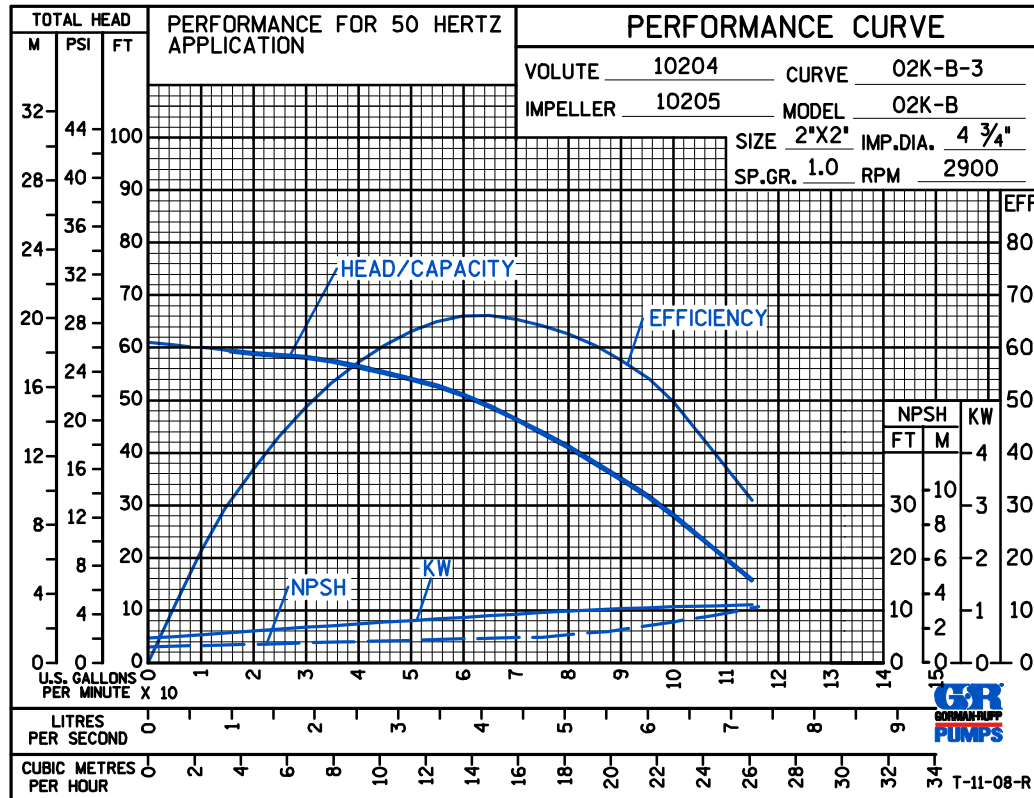

THE GORMAN-RUPP COMPANY • MANSFIELD, OHIO

GORMAN-RUPP OF CANADA LIMITED • ST. THOMAS, ONTARIO, CANADA

Specifications Subject to Change Without Notice

Printed in U.S.A.