

B

Basic Pump



Self Priming Centrifugal Pump

Model RS2A31-B and RS2A32-B

Size 3" x 2"

PUMP SPECIFICATIONS

Size: 3" x 2" (76 mm x 51 mm) Flanged.

Casing: (RS2A31-B) Ductile Iron 65-45-12.
(RS2A32-B) Cast Steel 70-36.

Maximum Operating Pressure 48 PSI (331 kPa).*

Enclosed Type, Four Vanes Impeller: Aluminum 356-T6.

Handles 1/4" (6,4 mm) Diameter Spherical Solids.

Impeller Shaft: Steel 1045.

Rotor: Copper Alloy C93200.

Bearing Housing: Ductile Iron 65-45-12.

Bearing Housing Lubrication: Grease.

Body Cover: (RS2A31-B) Ductile Iron 65-45-12.
(RS2A32-B) Cast Steel 70-36.

Center/Spacer Plate: (RS2A31-B) Ductile Iron 65-45-12.
(RS2A32-B) Cast Steel 70-36.

Radial Bearing: Permanently Sealed Single Row Ball Type.

Thrust Bearing: Permanently Sealed Single Row Ball Type.

Gaskets: Vegetable Fiber, PTFE and Cork.

Priming: Rotary Vane Type with Built-in Spring-Loaded Priming Assist Valve.

Optional Equipment: Cast Steel 70-36 Threaded Suction and Discharge Companion Flange Kit, Copper Alloy C93700 Impeller, Group Grind with Cast Iron Rotor (RS2A31-B Only), Stainless Steel 416 Impeller Shaft, Buna-N Seal, PTFE Seal with Viton O-Ring, PTFE Seal with Buna-N O-Ring, Oil Filled Bearing Housing Assembly.

*Consult Factory for Applications Exceeding Maximum Pressure and/or Temperature Indicated.

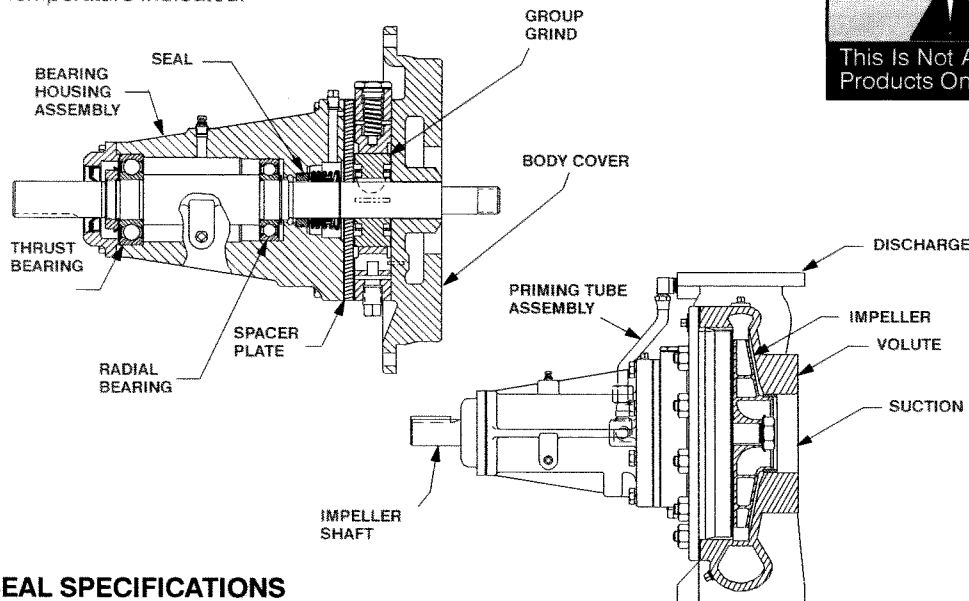
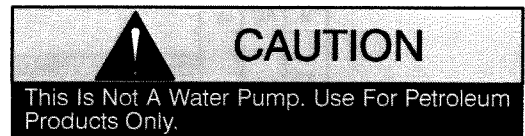
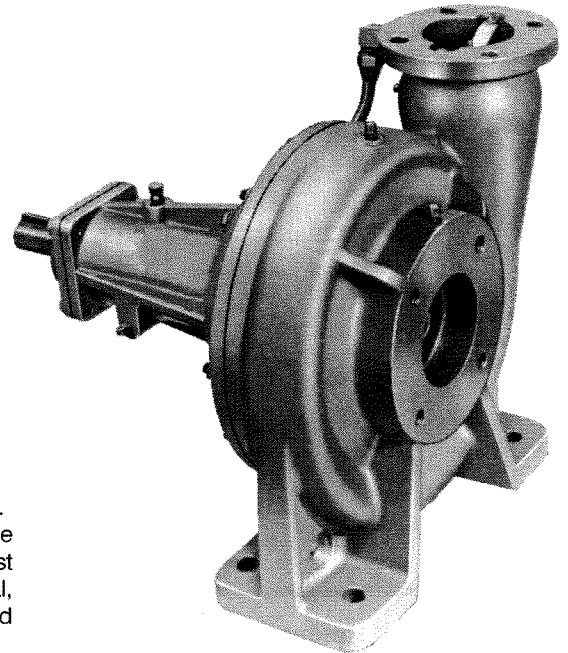

SEAL AREA DETAIL

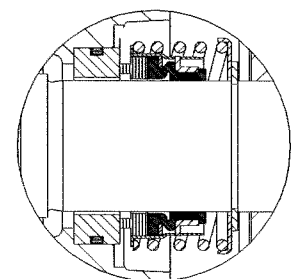

SEAL SPECIFICATIONS

Seal: Mechanical; Self-Lubricated. Fluorocarbon Elastomers (DuPont Viton® or Equivalent). Carbon Rotating Face; Ni-Resist Stationary Face; Maximum Temperature of Liquid Pumped is 160°F (71°C).*



THE GORMAN-RUPP COMPANY • MANSFIELD, OHIO

GORMAN-RUPP OF CANADA LIMITED • ST. THOMAS, ONTARIO, CANADA

www.grpumps.com

Specifications Subject to Change Without Notice

Printed in U.S.A.

